

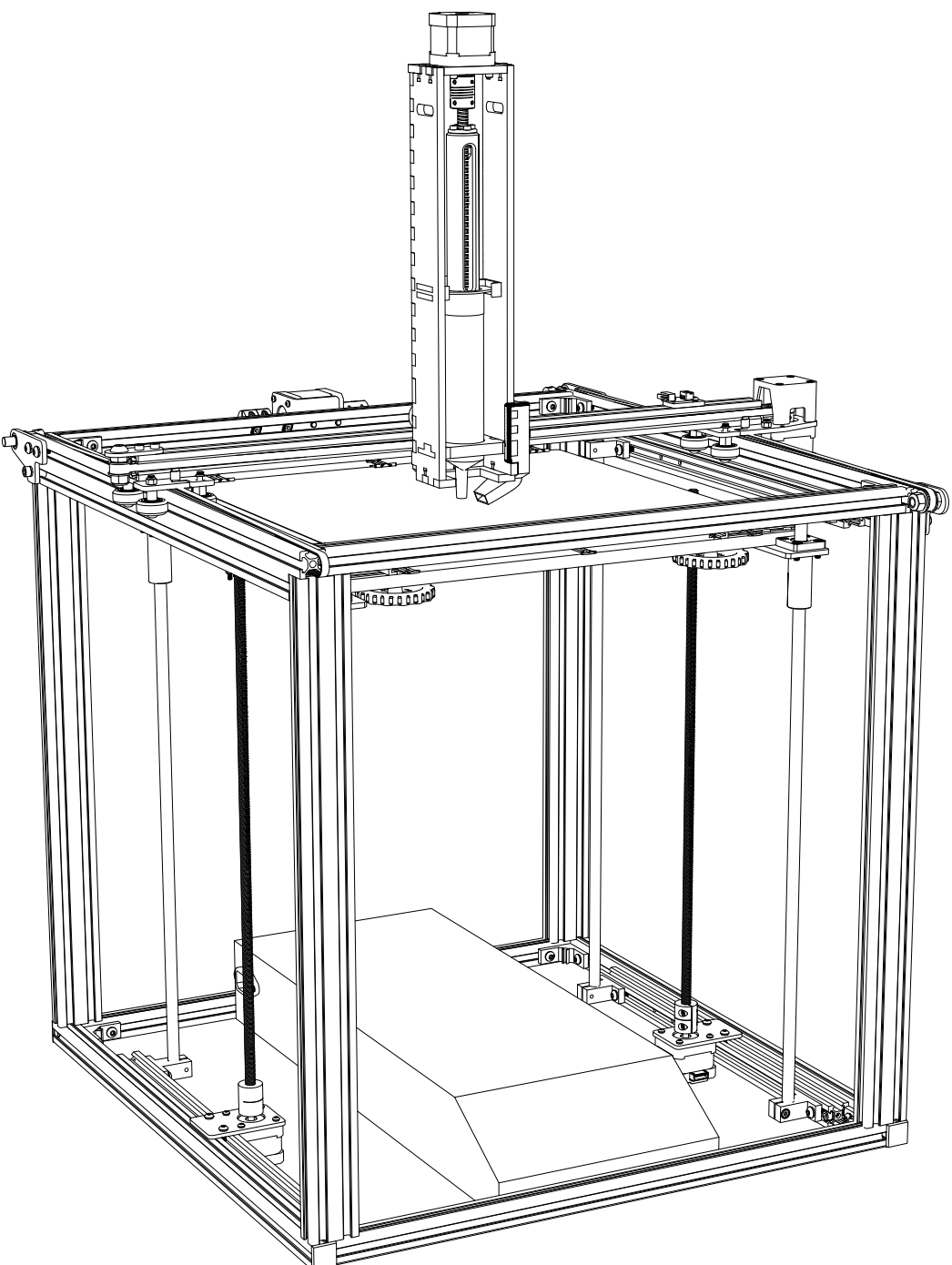

Mechanical Paste Extruder Assembly Ender 5 Plus





Junai has a mission to make Paste 3D printing as accessible as possible.

In order to achieve this goal we have worked on creating an extruder that is compatible with most pastes and desktop 3D printers on the market. After testing and evaluating other open-source designs, by mixing some parts and improving others we have created the current extruder. Its parts are carefully selected and widely available. The 3D printed parts are kept to a minimum and the lasercut press-fit design of the frame makes it more sustainable to produce and allows quick assembly.

The current version is compatible with **Creativity CR10 V3, Ender 3V2 and Ender 5 plus** 3D printers. Attachments for other brands and models will follow soon. If you would like to use it on a different printer setup, you can modify the position of the screw holes on the back side of the extruder.

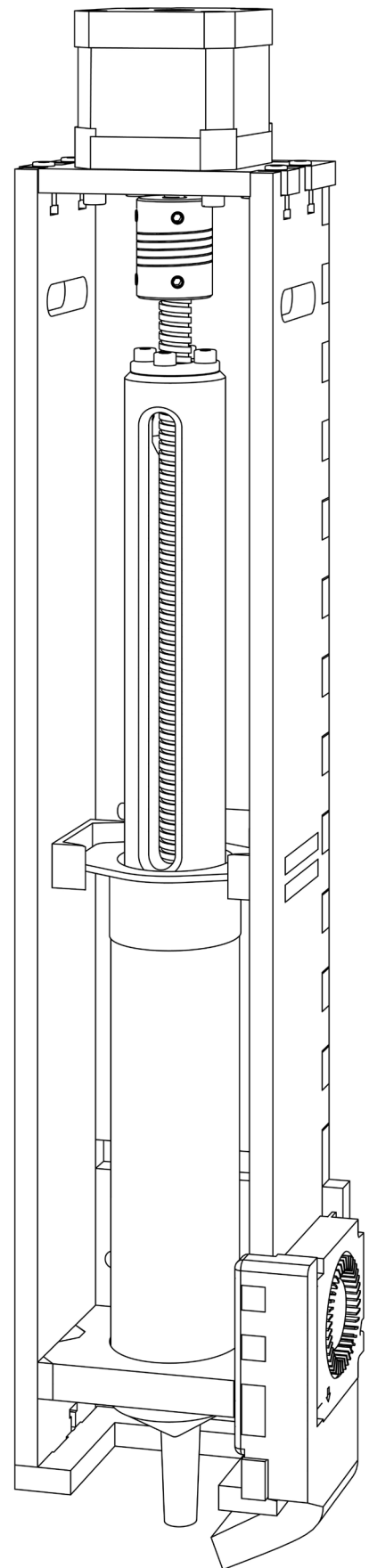

How to convert your Ender 5 Plus to Paste Extrusion?

1

Open the control box by removing the 6 screws at the bottom of your printer base. Disconnect the cables connected to your extruder bundle, such as the one for the stepper motor, nozzle heating and cooling, etc. The only one which needs to stay in place is the one connected to the side fan, used to cool your prints. Tip: Keep the box open, you will need access to the screen motherboard for uploading new firmware.



2

Remove the entire extruder and hot end assembly. Leave only the cooling fan on the side of the hot end.

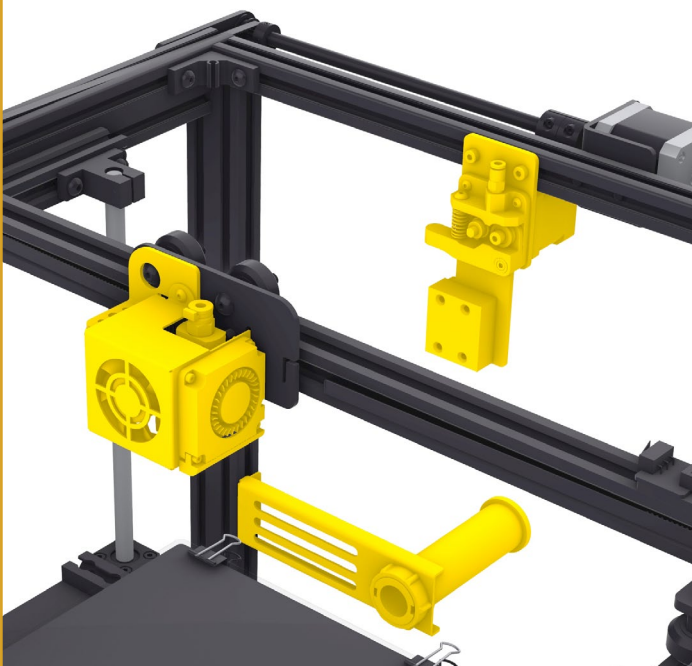

3

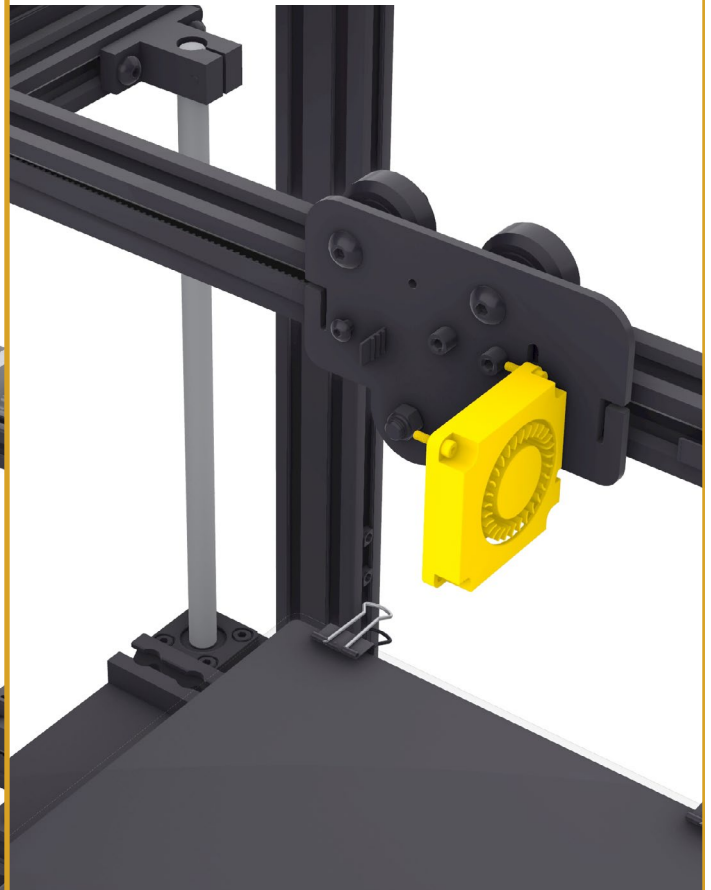

Assembling instructions

1

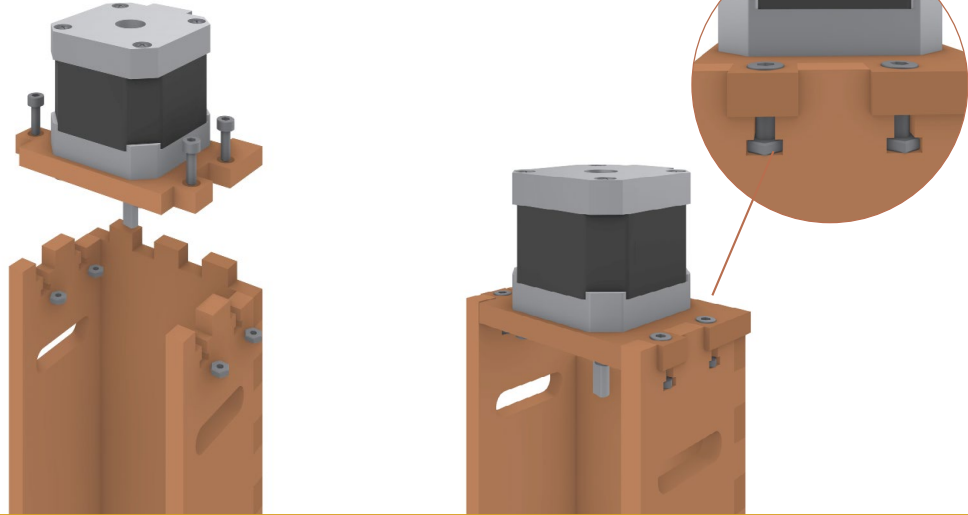

2

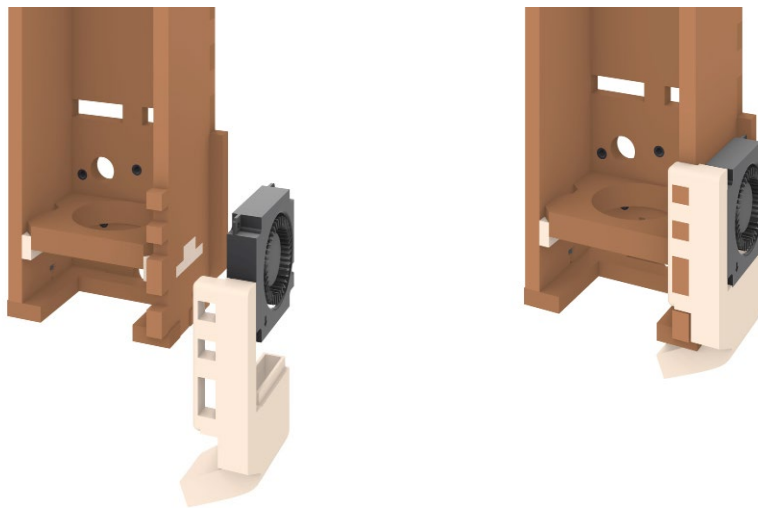

3

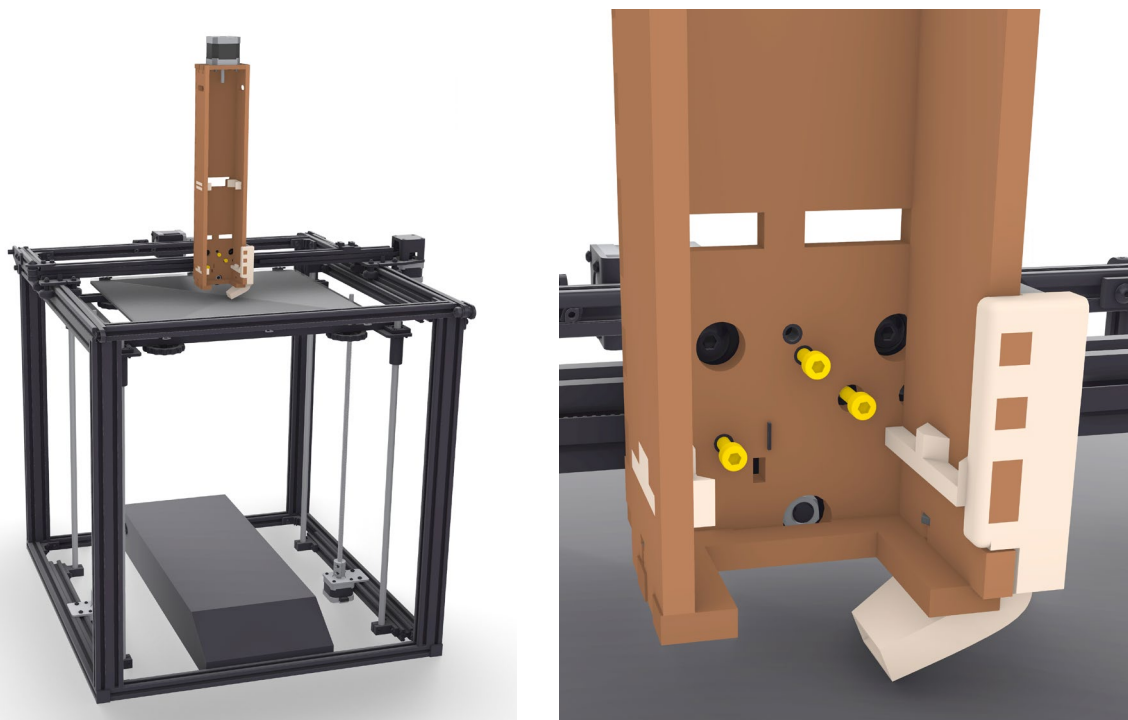

4

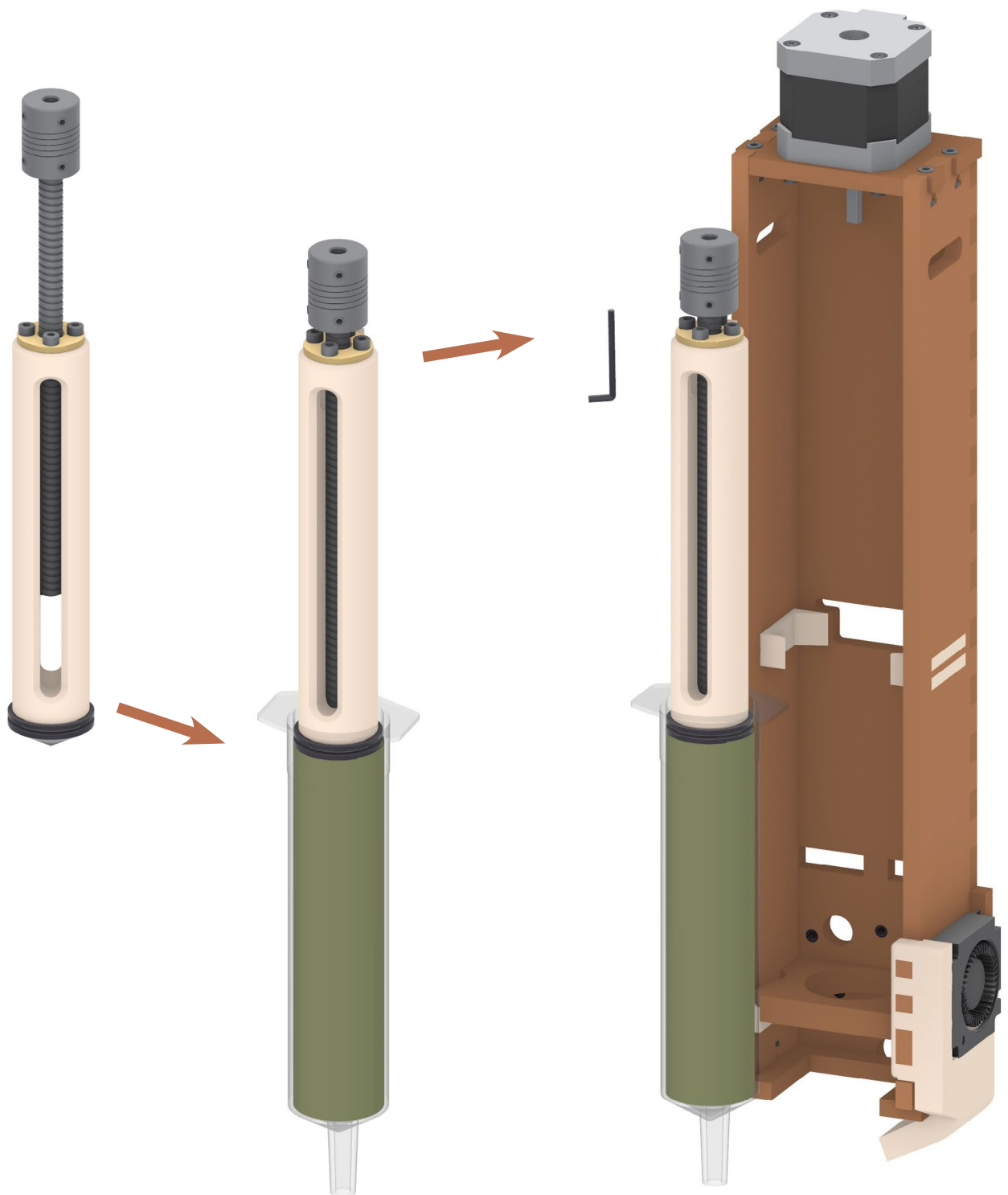

5



Firmware update and slicing

Please scan the QR code below to access the files needed to complete this step located in a shared drive folder. To access them directly, please follow these links:

Cura start&end .gcode [link](#)

Paste extruder cura profile [link](#)

At this moment you will need to upload new firmware to your printer. Before starting, please make sure you download the folders **xLoader** and **DWIN_SET** and the **firmware_ender5plus.hex** file.

1. Main board update: Next, switch off your 3D printer if it was on and plug it off the electricity. Connect your computer with the 3D printer (use the blue usb cable) and run the XLoader.exe file. Choose the downloaded .hex file and the COM port corresponding to your printer.

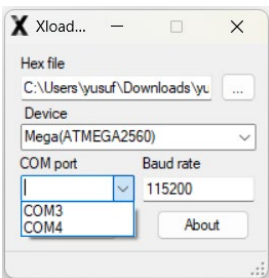

Press "Upload" and wait for around 2 minutes until the firmware is updated. You will see when the process is completed on the screen and after that, disconnect the printer from your computer.

2. LCD screen update: Format an empty 8GB SD card and place the DWIN_SET folder in it. Take the card and place it in the dedicated slot on the main board of the printer screen (it is located in the control box). Turn the printer on and wait for a few minutes until the screen firmware is flashed too. Once it is completed, switch the printer off, remove the card and close the control box.

Next, **load the custom Cura profile and paste the start and end .gcode** we have placed in the drive folder. Simply open your Cura slicing software and follow the instructions shown in these images.

*In step 3 choose the type of printer you are currently working with.



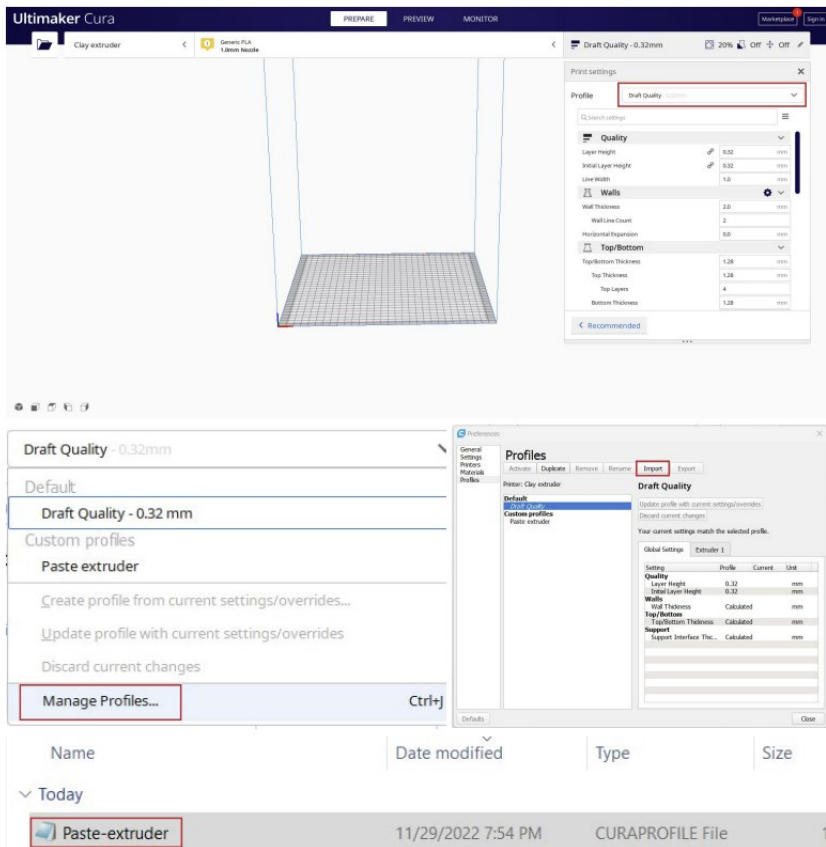
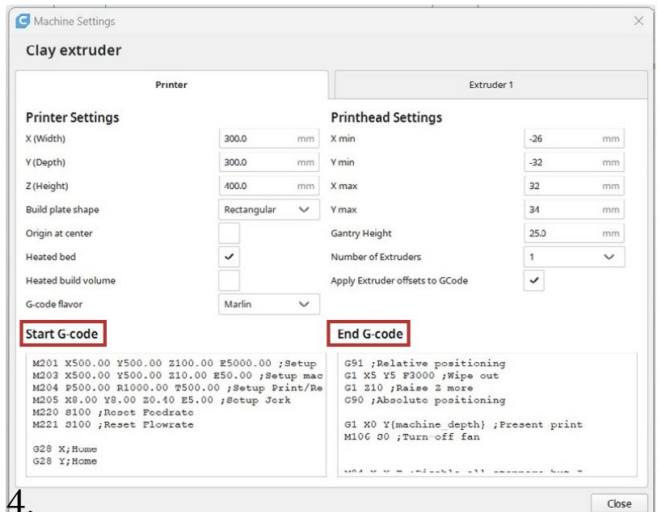
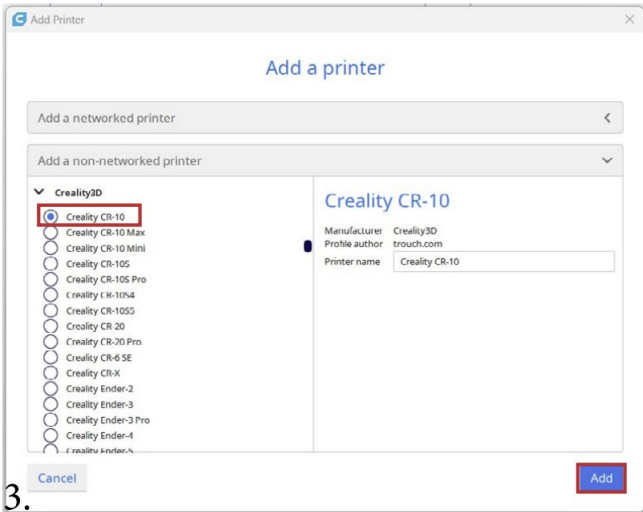
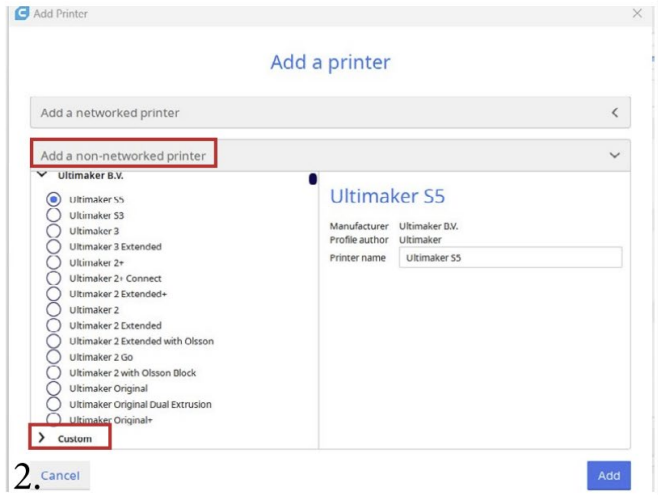
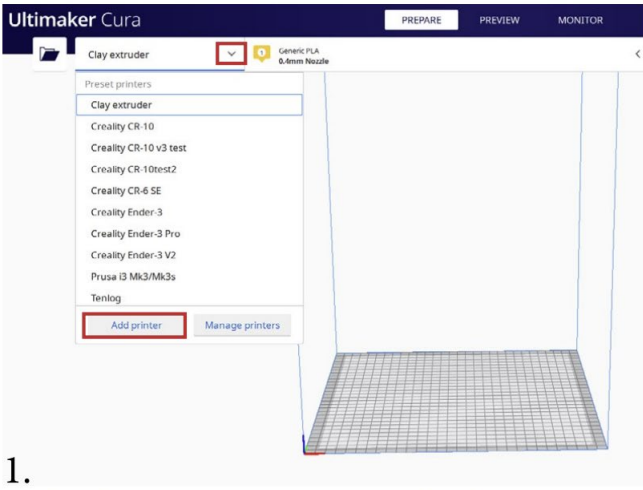

Bed Leveling

Just like with a normal plastic printing setup you have to place a piece of paper under the nozzle and with the help of the screws located on the 4 corners below the bed, you can manually adjust the position of your printing surface.

This step is crucial in order to avoid damaging your extruder or print bed.

Slicing

After setting up the printer and loading the profile you can upload your file and slice it. Feel free to change the settings according to your wish and printing material. You will need to fine-tune the numbers with every different material in order to make the perfect print.

Upload the .gcode to the memory card included in the box and place it in the sd card reader slot on the printer's control box.

Finally, you can start your print file.

That's all!

Happy printing!





Biomaterials loved by nature

Jasper Middendorp

+31651471308

jasper@junai.earth

